

CBSE Test Paper 04
Chapter 12 Area Related to Circle

1. The angle described by the minute hand between 4.00 pm and 4.25 pm is **(1)**
 - a. 90°
 - b. 150°
 - c. 125°
 - d. 100°
2. Four circles each of radius 'a' touch each other. The area between them is **(1)**
 - a. None of these
 - b. $\frac{6}{7}a^2$
 - c. $\frac{6}{7}a$
 - d. $\frac{7}{6}a^2$
3. The area of a square that can be inscribed in a circle of radius 10 cm is **(1)**
 - a. 100 sq. cm
 - b. 300 sq. cm
 - c. 200 sq. cm
 - d. 150 sq. cm
4. The radius of the circle whose area is equal to the sum of the areas of the two circles of radii 24cm and 7cm is **(1)**
 - a. 24cm
 - b. 7cm
 - c. 25cm
 - d. 31cm
5. Area of the largest circle that can be inscribed in a semicircle of radius 'r' units is **(1)**
 - a. $\frac{r^2}{\sqrt{2}}$ sq.units
 - b. $\frac{r^2}{2}$ sq.units
 - c. $(\pi/4)r^2$ sq.units
 - d. $\sqrt{2}r^2$ sq.units
6. Find the ratio of the area of the incircle and circumcircle of a square. **(1)**

7. What will be the perimeter of a quadrant of a circle of radius r cm? **(1)**
8. What is the diameter of a circle whose area is equal to the sum of the areas of two circles of radii 40 cm and 9 cm? **(1)**
9. The area of the sector of a circle of radius 10.5 cm is 69.3 cm^2 . Find the central angle of the sector. **(1)**
10. A garden roller has a circumference of 4 m. Find the number of revolutions, it makes in moving 40 m. **(1)**
11. Find the area of the shaded region **(2)**

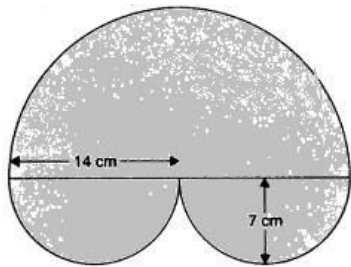

12. A sector is cut from a circle of radius 21 cm. The angle of the sector is 150° . Find the length of its arc and area. **(2)**
13. A circular grassy plot of land, 42 m in diameter, has a path 3.5 m wide running around it on the outside. Find the cost of travelling the path at Rs.4 per square metre. **(2)**
14. The outer circumference of a circular race-track is 528 m. The track is everywhere 14 m wide. Calculate the cost of levelling the track at the rate of 50 paise per square metre (Use $\pi = \frac{22}{7}$) **(3)**
15. A round table cover has six equal designs, as shown in the figure. If the radius of the cover is 28 cm, find the cost of making the designs at the rate of Rs. 0.35 per cm^2 . [Use $\sqrt{3} = 1.7$.] **(3)**

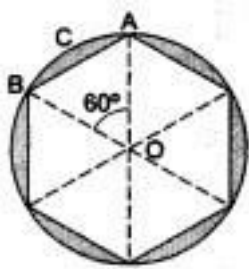

16. In the given figure, AOB is a sector of angle 60° of a circle with centre O and radius 17 cm. If $AP \perp OB$ and $AP = 15$ cm, find the area of the shaded region. **(3)**

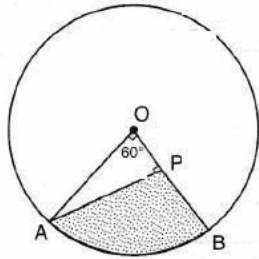

17. In the given figure, ABCD is a rectangle with $AB = 80$ cm and $BC = 70$ cm, $\angle AED = 90^\circ$ and $DE = 42$ cm. A semicircle is drawn, taking BC as diameter. Find the area of the shaded region. **(3)**

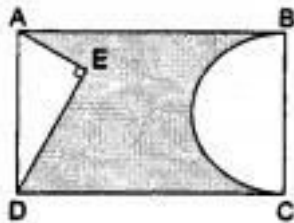

18. AB is one of the direct common tangent of two circles of radii 12 cm and 4 cm respectively touching each other. Find the area of the region enclosed by the circles and the tangent. **(4)**
19. Find the difference of the areas of two segments of a circle formed by a chord of length 5 cm subtending angle of 90° at the centre. **(4)**
20. PQRS is a diameter of a circle of radius 6 cm. The lengths PQ, QR and RS are equal. Semicircles are drawn with PQ and as diameters, as shown in the given figure. If $PS = 12$ cm, find the perimeter and area of the shaded region. [Take $\pi = 3.14$.] **(4)**

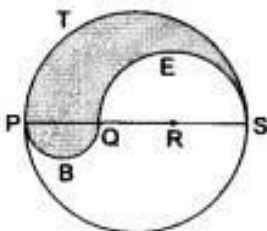

CBSE Test Paper 04
Chapter 12 Area Related to Circle

Solution

1. b. 150°

Explanation: Time duration between 4.00 pm and 4.25 pm = 25 minutes

\therefore Angle described by minute hand in 60 minutes = 360°

\therefore Angle described by minute hand in 25 minutes = $\frac{360^\circ}{60^\circ} \times 25 = 150^\circ$

2. b. $\frac{6}{7}a^2$

Explanation: Area of required region = Area of square – Area of 4 quadrant

$$\Rightarrow \text{Area of required region} = (2a)^2 - 4 \times \frac{1}{4} \times \frac{22}{7} \times a^2$$

$$= 4a^2 - \frac{22}{7}a^2$$

$$= \frac{6}{7}a^2 \text{ sq. cm}$$

3. c. 200 sq. cm

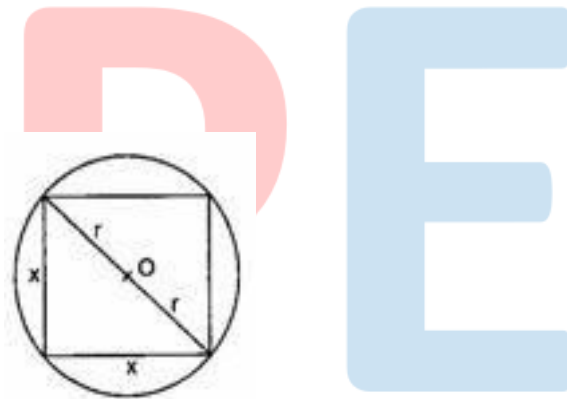

Explanation:

Given: Radius (r) = 10 cm

Let the side of the square be x cm

Now, using Pythagoras theorem,

$$x^2 + x^2 = (2r)^2$$

$$2x^2 = (20)^2$$

$$\Rightarrow 2x^2 = 400$$

$$x^2 = 200 \text{ sq. cm}$$

Therefore, the area of the square = 200 sq. cm.

4. c. 25cm

Explanation: Let required radius be R .

Then according to the question,

$$\pi R^2 = \pi r_1^2 + \pi r_2^2$$

$$= \pi (r_1^2 + r_2^2)$$

$$\begin{aligned}\Rightarrow R^2 &= r_1^2 + r_2^2 \\ \Rightarrow R^2 &= (24)^2 + (7)^2 = 576 + 49 = 625 \\ \Rightarrow R &= 25 \text{ cm}\end{aligned}$$

5. c. $(\pi/4)r^2$ sq.units

Explanation: Here, Diameter of circle = Radius of semicircle = r



$$\begin{aligned}\therefore \text{Radius of the circle} &= \frac{r}{2} \\ \therefore \text{Area of the circle} &= \pi \left(\frac{r}{2}\right)^2 = \frac{\pi r^2}{4} \\ \therefore (\pi/4)r^2 \text{sq.units}\end{aligned}$$

6. Let the side of square = x units

Diagonal of the square = $\sqrt{2}x$ units

Diameter of the incircle = x units

Diameter of the circumcircle = $\sqrt{2}x$ units

$$\frac{\text{Area of incircle}}{\text{Area of circumcircle}} = \frac{\pi \left(\frac{x}{2}\right)^2}{\pi \left(\frac{\sqrt{2}x}{2}\right)^2} = \frac{1}{2}$$

Ratio = 1 : 2

7. Circumference of circle = $2\pi r$

length of the arc of quadrant = $\frac{1}{4} \times 2\pi r = \frac{\pi r}{2}$

Perimeter of a quadrant = $r + r + \frac{1}{2} \times \pi r = 2r + \frac{1}{2} \times \pi r = \frac{r}{2}(\pi + 4)$ cm

Therefore, perimeter of the quadrant with radius "r" = $\frac{r}{2}(\pi + 4)$ cm

8. Area of the circle = sum of areas of two circles

$$\pi r^2 = \pi \times (40)^2 + \pi(9)^2$$

$$\text{or, } r^2 = 1600 + 81$$

$$\text{or, } r = \sqrt{1681}$$

$$= 41 \text{ cm.}$$

Diameter of circle is double of radius.

$$\therefore \text{Diameter of given circle} = 2 \times r$$

$$= 41 \times 2$$

$$= 82 \text{ cm.}$$

9. It is given that area of the sector = 69.3 cm^2

and Radius = 10.5 cm

$$\text{Now, Area of the sector} = \frac{\pi r^2 \theta}{360}$$

$$\Rightarrow \frac{\pi \times (10.5)^2 \times \theta}{360} = 69.3$$

$$\Rightarrow \theta = \frac{69.3 \times 360 \times 7}{10.5 \times 10.5 \times 22} = 72^\circ$$

Therefore, Central angle of the sector = 72°

10. Given, Circumference of circle = 4 m

Total distance covered by roller = 40 m

Distance covered in one Revolution = circumference of roller = 4 m

$$\text{Number of revolution} = \frac{\text{Total Distance covered by roller}}{\text{Distance covered in one revolution}}$$

$$= \frac{40}{4} = 10 \text{ revolutions}$$

Total revolution = 10 .

11. Radius of the larger semicircle 14 cm

\therefore Area of the larger semicircle

$$= \frac{1}{2} \pi (14)^2 = \frac{1}{2} \times \frac{22}{7} \times 196$$

$$= 308 \text{ cm}^2$$

Radius of each smaller semicircle = 7 cm

\therefore Area of two smaller semicircles

$$= 2 \left[\frac{1}{2} \times \pi (7)^2 \right]$$

$$= \frac{22}{7} \times (7)^2 = 154 \text{ cm}^2$$

\therefore The area of the shaded region

$$= 308 \text{ cm}^2 + 154 \text{ cm}^2 = 462 \text{ cm}^2$$

12. The arc length l and area A of a sector of angle θ in a circle of radius r are is given by

$$l = \frac{\theta}{360} \times 2\pi r \text{ and } A = \frac{\theta}{360} \times \pi r^2 \text{ respectively.}$$

Here, $r = 21 \text{ cm}$ and $\theta = 150$

$$\therefore l = \left\{ \frac{150}{360} \times 2 \times \frac{22}{7} \times 21 \right\} \text{ cm} = 55 \text{ cm}$$

$$\text{and, } A = \left\{ \frac{150}{360} \times \frac{22}{7} \times (21)^2 \right\} \text{ cm}^2 = \frac{1155}{2} \text{ cm}^2 = 577.5 \text{ cm}^2$$

13.

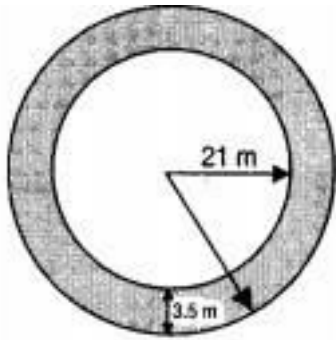

Radius of the plot = 21 m. Radius of the plot including the path = $(21 + 3.5) \text{ m} = 24.5 \text{ m}$

\therefore Area of the path

$$= \{ \pi(24.5)^2 - (21)^2 \} \text{ m}^2$$

$$= \pi \{ (24.5 + 21) (24.5 - 21) \} \text{ m}^2$$

$$= \{ \pi(45.5) \times (3.5) \} \text{ m}^2$$

$$= \frac{22}{7} \times 45.5 \times 3.5 \text{ m}^2 = 500.5 \text{ m}^2$$

Hence, cost of gravelling the path = Rs $(500.5 \times 4) = \text{Rs } 2002$.

14.

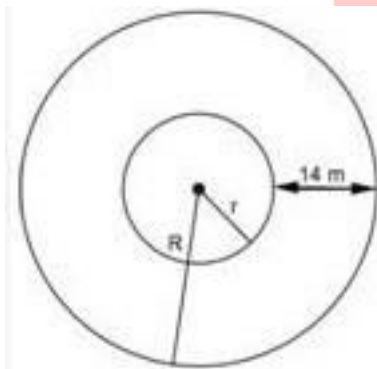

Let, radius of inner circle = $r \text{ m}$

radius of outer circle = $R \text{ m}$

width of track = 14m

Given,

Outer circumference = 528m

$$\Rightarrow 2\pi R = 528 \text{ m}$$

$$\Rightarrow 2 \times \frac{22}{7} \times R = 528$$

$$\Rightarrow R = \frac{528 \times 7}{2 \times 22} = 84 \text{ m}$$

the inner radius = $84 - 14 = 70 \text{ m}$

\therefore Area of track = Area of outer circle - Area of inner circle

$$= \frac{22}{7} \times 84 \times 84 - \frac{22}{7} \times 70 \times 70$$

$$= \frac{22}{7} \times 7 \times 7 [12 \times 12 - 10 \times 10]$$

$$= 6776 \text{ m}^2$$

Rate of levelling the track = 50 paise per m^2

$$\therefore \text{Total cost of levelling} = 6776 \times 50$$

$$= 338800 \text{ paise}$$

$$= \text{Rs } 3388$$

15. Let O be the centre of the table cover and let it be divided into six equal designs, each being a segment. Let one of these segments be ACBA. Clearly,

$$\angle AOB = \left(\frac{360}{6}\right)^\circ = 60^\circ.$$

$$\text{ar}(\text{segment ACBA}) = \text{ar}(\text{sector OACBO}) - \text{ar}(\text{equilateral } \triangle OAB)$$

$$= \left(\frac{\pi r^2 \theta}{360} - \frac{\sqrt{3}}{4} a^2\right)$$

$$= \left[\left(\frac{22}{7} \times 28 \times 28 \times \frac{60}{360}\right) - \left(\frac{\sqrt{3}}{4} \times 28 \times 28\right)\right] \text{ cm}^2 [\because a = OA = 28\text{cm}]$$

$$= \left(\frac{1232}{3} - \frac{17}{10} \times 7 \times 28\right) \text{ cm}^2$$

$$= \left(\frac{1232}{3} - \frac{1666}{5}\right) \text{ cm}^2$$

$$= \frac{(6160 - 4998)}{15} \text{ cm}^2$$

$$= \frac{1162}{15} \text{ cm}^2$$

$$\text{ar}(\text{all the six segment}) = \left(\frac{1162}{15} \times 6\right) \text{ cm}^2$$

$$= \frac{2324}{5} \text{ cm}^2$$

$$\text{Cost of designs} = \text{Rs} \left(\frac{2324}{5} \times \frac{35}{100}\right)$$

$$= \text{Rs} 162.28$$

16.

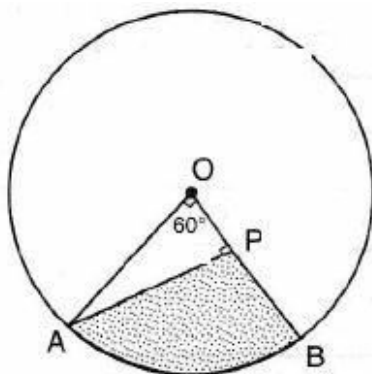

As $OA = 17 \text{ cm}$, $AP = 15 \text{ cm}$ and $\triangle OPA$ is right triangle

\therefore Using Pythagoras theorem,

$$OP = 8 \text{ cm}$$

Area of the shaded region = Area of the sector AOB - Area of $\triangle OPA$

$$\begin{aligned}
 &= \frac{60}{360} \times \pi r^2 - \frac{1}{2} \times b \times h \\
 &= \frac{60^\circ}{360^\circ} \times \frac{22}{7} \times 17 \times 17 - \frac{1}{2} \times 8 \times 15 \\
 &= \frac{1^\circ}{60^\circ} \times \frac{22}{7} \times 17 \times 17 - 4 \times 15 \\
 &= \frac{1^\circ}{60^\circ} \times \frac{22}{7} \times 289 - 60 \\
 &= 151.38 - 60 \\
 &= 91.38 \text{ cm}^2
 \end{aligned}$$

So, area of the shaded region is 91.38 cm².

17. Length of rectangle ABCD

$$= AB = 80\text{cm}$$

Breadth of rectangle ABCD

$$= BC = 70\text{cm}$$

\therefore Area of rectangle ABCD

$$= AB \times BC$$

$$= 80 \times 70$$

$$= 5600 \text{ cm}^2$$

In right-angled $\triangle AED$,

$$AE^2 = (AD^2 - DE^2)$$

$$= (70^2 - 42^2)$$

$$= (70 + 42)(70 - 42)$$

$$= 112 \times 28$$

$$= 4 \times 28 \times 28$$

$$= 2 \times 28$$

$$= 56 \text{ cm}$$

\therefore Area of $\triangle AED$

$$= \frac{1}{2} \times DE \times AE$$

$$= \frac{1}{2} \times 42 \times 56$$

$$= 1176 \text{ cm}^2$$

$$\text{Area of semi-circle} = \frac{1}{2} \pi \times \left(\frac{70}{2}\right)^2$$

$$= \left\{ \frac{1}{2} \times \frac{22}{7} \times 35 \times 35 \right\} \text{ cm}^2$$

$$= 1925 \text{ cm}^2$$

Thus, Area of the shaded region

$$= \text{Area of rectangle ABCD} - (\text{Area of } \triangle AED + \text{Area of semi-circle})$$

$$= 5600 - (1176 + 1925)$$

$$= 5600 - 3101$$

$$= 2499 \text{ cm}^2$$

18. Let tangent touches the circles with centre O and O' at the points A and B respectively.

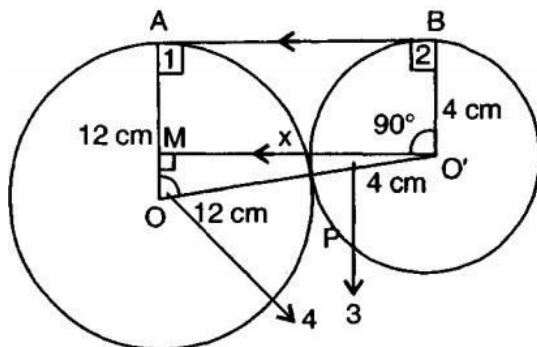

$\Rightarrow \angle 1 = \angle 2 = 90^\circ$ [tangent makes right angle with the radius at the point of contact]

Through O' draw $O'M \parallel AB$ meeting OA in M

$\Rightarrow O'M \parallel AB$.

Thus, ABO'M is a rectangle with $AM = O'B = 4 \text{ cm}$

In triangle OMO',

$$OM = OA - AM$$

$$= (12 - 4) \text{ cm} = 8 \text{ cm}$$

$$\text{and } OO' = OP + O'P = 12 + 4 = 16 \text{ cm}$$

$$\Rightarrow OO'^2 = OM^2 + (O'M)^2$$

$$\Rightarrow x^2 = 16^2 - 8^2 = (16 - 8)(16 + 8)$$

$$= 8 \times 24 = 8 \times 8 \times 3$$

$$\Rightarrow x = \sqrt{8 \times 8 \times 3} = 8\sqrt{3} \text{ cm}$$

Area ABO'O = area of rectangle ABO'M + area of $\triangle OMO'$

$$= AM \times O'M + \frac{1}{2} \times OM \times O'M$$

$$= 4 \times 8\sqrt{3} + \frac{1}{2} \times 8 \times 8\sqrt{3}$$

$$= 32\sqrt{3} + 32\sqrt{3} = 64\sqrt{3} \text{ cm}$$

Now, $\triangle OMO'$ is a right triangle with $\angle M = 90^\circ$

$$\begin{aligned} \frac{O'M}{OO'} &= \frac{8\sqrt{3}}{16} = \cos(\angle 3) \\ \Rightarrow \angle 3 &= 30^\circ \text{ and } \frac{OM}{OO'} = \cos \angle 4 \\ \Rightarrow \frac{8}{16} &= \cos \angle 4 \\ \angle 4 &= 60^\circ \\ \Rightarrow \angle AOP &= 60^\circ \\ &= \text{angle of sector AOP} \\ \angle 3 = 30^\circ &\Rightarrow \angle MO'O = 30^\circ \\ \Rightarrow \angle BO'P &= 90^\circ + \angle MO'O = 90^\circ + 30^\circ \\ &= 120^\circ = \text{angle of sector BOP} \end{aligned}$$

Area of the portion enclosed between the circles and the tangents is

$$\begin{aligned} &= \text{area of trapezium ABO'O} - 2(\text{area of the sectors}) \\ &= 64\sqrt{3} \text{ cm}^2 - (\text{area of sector AOP} + \text{area of sector BO'P}) \\ &= 64\sqrt{3} \text{ cm}^2 - \left[\frac{60^\circ}{360^\circ} \times \pi \times 12^2 + \frac{120^\circ}{360^\circ} \times \pi \times 4^2 \right] \text{ cm}^2 \\ &= 64\sqrt{3} \text{ cm}^2 - \frac{\pi}{6} [144 + 2 \times 16] \text{ cm}^2 \\ &= 64\sqrt{3} \text{ cm}^2 - \frac{\pi}{6} \times 8 [18 + 2 \times 2] \text{ cm}^2 \\ &= 64\sqrt{3} \text{ cm}^2 - \frac{4\pi}{3} \times 2 [9 + 2] \text{ cm}^2 \\ &= \left[64\sqrt{3} - \frac{8}{3} \times \pi \times 11 \right] \text{ cm}^2 \\ &= \left[64 \times 1.73 - \frac{88}{3} \times \frac{22}{7} \right] \text{ cm}^2 \\ [110.72 - 92.1904] &= 18.5296 \text{ cm}^2 \end{aligned}$$

19. Chord AB = 5 cm divides the circle into two segments minor segment APB and major segment AQB. We have to find out the difference in area of major and minor segment.

Here, we are given that $\theta = 90^\circ$

$$\text{Area of } \triangle OAB = \frac{1}{2} \text{ Base} \times \text{Altitude} = \frac{1}{2} r \times r = \frac{1}{2} r^2$$

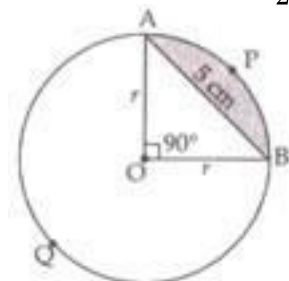

Area of minor segment APB

$$\begin{aligned} &= \frac{\pi r^2 \theta}{360^\circ} - \text{Area of } \triangle AOB \\ &= \frac{\pi r^2 90^\circ}{360^\circ} - \frac{1}{2} r^2 \end{aligned}$$

$$\Rightarrow \text{Area of minor segment} = \left(\frac{\pi r^2}{4} - \frac{r^2}{2} \right) \dots(i)$$

Area of major segment AQB = Area of circle - Area of minor segment

$$= \pi r^2 - \left[\frac{\pi r^2}{4} - \frac{r^2}{2} \right]$$

$$\Rightarrow \text{Area of major segment AQB} = \left[\frac{3}{4} \pi r^2 + \frac{r^2}{2} \right] \dots(ii)$$

Difference between areas of major and minor segment

$$= \left(\frac{3}{4} \pi r^2 + \frac{r^2}{2} \right) - \left(\frac{\pi r^2}{4} - \frac{r^2}{2} \right)$$

$$= \frac{3}{4} \pi r^2 + \frac{r^2}{2} - \frac{\pi r^2}{4} + \frac{r^2}{2}$$

$$\Rightarrow \text{Required area} = \frac{2}{4} \pi r^2 + r^2 = \frac{1}{2} \pi r^2 + r^2$$

In right $\triangle OAB$,

$$r^2 + r^2 = AB^2$$

$$\Rightarrow 2r^2 = 5^2$$

$$\Rightarrow r^2 = \frac{25}{2}$$

$$\text{Therefore, required area} = \left[\frac{1}{2} \pi \times \frac{25}{2} + \frac{25}{2} \right] = \left[\frac{25}{4} \pi + \frac{25}{2} \right] \text{ cm}^2$$

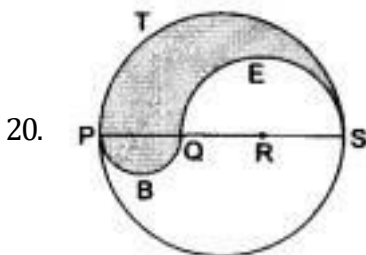

$$\text{Perimeter (Circumference of circle)} = 2\pi r$$

We know:

$$\text{Perimeter of a semicircle arc} = \pi r$$

Now,

For the arc PTS, radius is 6 cm.

Therefore, Circumference of the semicircle PTS

$$= \pi r = 6\pi \text{ cm}$$

For the arc QES, radius is 4 cm.

Therefore, Circumference of the semicircle QES

$$= \pi r = 4\pi \text{ cm}$$

For the arc PBQ, radius is 2 cm.

Therefore, Circumference of the semicircle PBQ

$$= \pi r = 2\pi \text{ cm}$$

Now, perimeter of the shaded region

$$= 6\pi + 4\pi + 2\pi$$

$$= 12\pi$$

$$12 \times 3.14$$

$$= 37.68 \text{ cm}$$

$$\text{Area of the semicircle} = \frac{1}{2} \pi r^2$$

$$= \frac{1}{2} \times 3.14 \times 2 \times 2$$

$$= 6.28 \text{ cm}^2$$

$$\text{Area of the semicircle PTS} = \frac{1}{2} \pi r^2$$

$$= \frac{1}{2} \times 3.14 \times 6 \times 6$$

$$\text{Area of the semicircle QES} = \frac{1}{2} \pi r^2$$

$$= \frac{1}{2} \times 3.14 \times 4 \times 4$$

$$= 25.12 \text{ cm}^2$$

Area of the shaded region

$$= \text{Area of the semicircle PBQ} + \text{Area of the semicircle PTS} - \text{Area of the semicircle QES}$$

$$= 6.28 + 56.52 - 25.12$$

$$= 37.68$$

PE