

CBSE Test paper 05

Chapter 12 Electricity and its Effects

1. To determine the equivalent resistance of a series combination of two resistors R_1 and R_2 , a student arranges the following set up : (1)

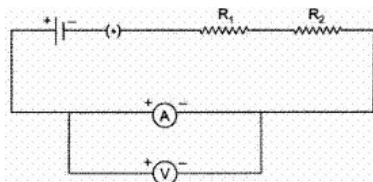

Which one of the following statements will be true for this circuit ? It gives :

- a. correct reading for potential difference V but incorrect reading for current I .
 - b. correct reading for current I but incorrect reading for potential difference V .
 - c. correct readings for both I and V
 - d. incorrect reading for current I as well as potential difference V .
2. Following circuits were drawn by four students, to determine the equivalent resistance of two resistors when connected in parallel. The correct circuit is drawn by the student. (1)

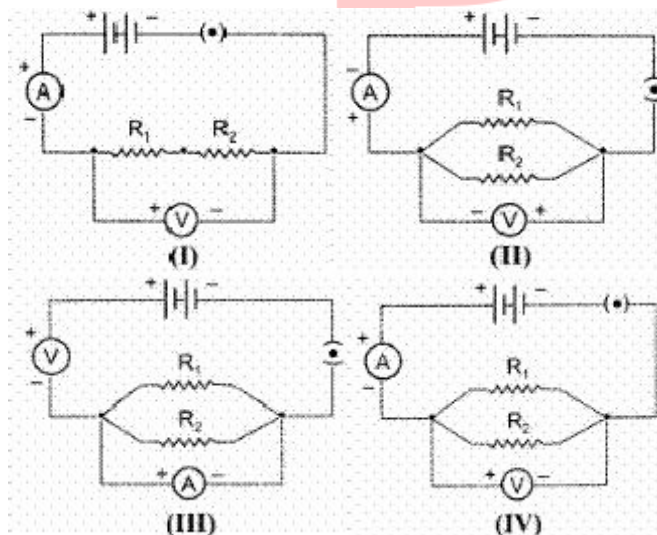

- a. III
 - b. II
 - c. I
 - d. IV
3. Two students (A) and (B) connect their two given resistors R_1 and R_2 in the manners shown below :

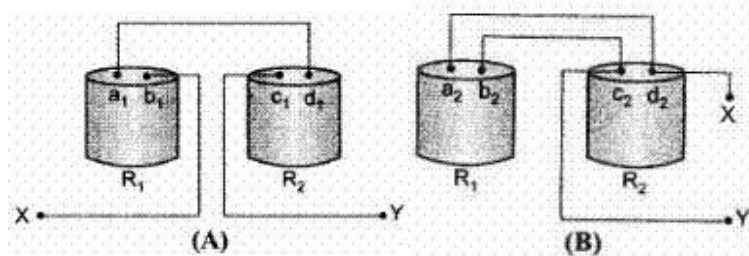

Student (A) connects the terminal marked (b_1) and (c_1) while student (B) connects the terminals marked (d_2) and (c_2) in their respective circuits at the points marked X and Y.

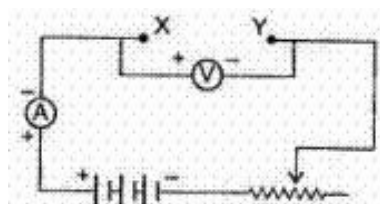

Which one of the following is correct in relation to above arrangements? (1)

- a. Student (A) will determine the equivalent resistance of the series combination while student (B) will determine the equivalent resistance of the parallel combination of the two resistors.
 - b. Both the students will determine the equivalent resistance of the parallel combination of the two resistors.
 - c. Both the students will determine the equivalent resistance of the series combination of the two resistors.
 - d. Student (A) will determine the equivalent resistance of the parallel combination while student (B) will determine the equivalent resistance of the series combination of the two resistors.
4. A wire of resistance $2\ \Omega$ is bent to form a circle. What is the resistance between two diametrically opposite points? (1)
- a. $0.5\ \Omega$
 - b. $4\ \Omega$
 - c. $1\ \Omega$
 - d. $1.5\ \Omega$
5. Match the following with the correct response: (1)

(1) Electric current	(A) Ammeter
(2) Small deflection in the circuit	(B) Battery

(3) Maintains potential difference between two points	(C) Galvanometer
(4) Variable Resistance	(D) Rheostat

a. 1-B, 2-D, 3-A, 4-C

b. 1-C, 2-B, 3-D, 4-A

c. 1-A, 2-C, 3-B, 4-D

d. 1-D, 2-A, 3-C, 4-B

6. Name the instrument used for measuring potential difference. **(1)**
7. What is resistance of dry air? **(1)**
8. You have two metallic wires of resistances 6Ω and 3Ω . How will you connect these wires to get an effective resistance of 2Ω ? **(1)**
9. Draw a circuit diagram using a battery of two cells, two resistors of 3Ω each connected in series, a plug key and a rheostat. **(1)**
10. On what factors does the resistance of a conductor depend? **(3)**
11. An electric motor takes 5A from a 220V line. Determine the power of the motor and the energy consumed in 2 h. **(3)**
12. An electric bulb is rated 220V and 100Ω . when operated on 110V, the power consumed will be **(3)**
1. 100Ω ;
 2. 75Ω
 3. 50Ω ;
 4. 25Ω .
13. An electric lamp of 100 ohms, a toaster of resistance 50 ohms and a water filter of resistance 500 ohms are connected in parallel to a 220V source. what is the resistance of the electric iron connected to the same source that takes as much current as all the three appliances and what is the current through it? **(3)**
14. Current I flowing through a resistor results in dissipation of power P. By what percentage will the power dissipated in the resistor increase, if the current through the resistor is increased by 50 percent? Justify your answer with the help of mathematical calculations. **(5)**
15. Redraw the circuit putting an ammeter to measure the current through the resistors and voltmeter to measure the potential difference across 12Ω resistor. what would be the reading in the ammeter and the voltmeter? **(5)**

CBSE Test paper 05
Chapter 12 Electricity and its Effects

Answers

1. d. incorrect reading for current I as well as potential difference V.
Explanation: Ammeter should not be shunted with voltmeter.
2. d. IV
Explanation: "V" has to be connected in parallel and the potential of +ve terminal is greater than -ve terminal.
3. a. Student (A) will determine the equivalent resistance of the series combination while student (B) will determine the equivalent resistance of the parallel combination of the two resistors.
Explanation: R_1 and R_2 has one common point in (A) and two common points in (B).
4. a. 0.5Ω
Explanation: When a wire of resistance 2Ω is bent to form a circle, the resistance between the two diametrically opposite points can be calculated as a parallel combination of two resistors of 1Ω each. The effective resistance of the two resistors will be 0.5Ω .
5. c. 1-A, 2-C, 3-B, 4-D
Explanation: An Ammeter (from Ampere Meter) is used to measure electric current (flow of electric charge) in an electric circuit. A Galvanometer is an electromechanical instrument for detecting and measuring small electric currents. A Battery maintains potential difference between two points in an electric circuit. A Rheostat is an electrical instrument used to control current in a circuit by varying the resistance.

(1) Electric current	(A) Ammeter
(2) Small deflection in the circuit	(C) Galvanometer
(3) Maintains potential difference between two points	(B) Battery

(4) Variable Resistance

(D) Rheostat

6. A voltmeter is an instrument used for measuring potential difference between two points in an electric circuit.
7. The resistance of dry air is infinity.
8. When the equivalent resistance of connecting wire is low then, wire should be connected in parallel combination. So equivalent resistance can be obtained by the given formula :

$$\therefore \frac{1}{R_{\text{eff}}} = \frac{1}{R_1} + \frac{1}{R_2} = \frac{1}{6} + \frac{1}{3} = \frac{1+2}{6} = \frac{3}{6} = \frac{1}{2}$$

$$\Rightarrow R_{\text{eff}} = 2\Omega$$

9. When we connect rheostat, key, battery of two cells and two resistors of three ohm each then required circuit diagram will be:

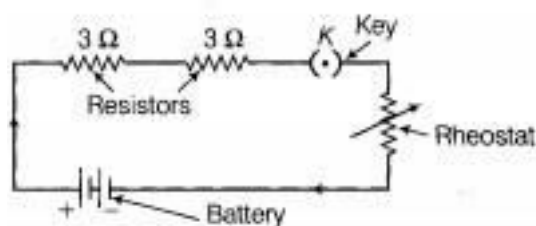

10. The resistance of a wire (R) depends on the following factors:
- Resistance is directly proportional to the length of the wire. $R \propto l$ (length of the conductor)
 - Resistance is inversely proportional to the area of cross-section of the wire.
 $R \propto \frac{1}{A}$ (area of cross - section)
 - $R \propto t$ (temperature)
 - R depends on the nature of material.

11. Power = $P = VI = 220 \times 5 = 1,100 \text{ W}$

Energy consumed in 2 h ($2 \times 60 \times 60$ s) $E = Pt$

$$E = (1,100) (2 \times 60 \times 60) = 7,920,000 \text{ J}$$

$$E = 7.92 \times 10^6 \text{ J.}$$

12. $P = \frac{V^2}{R}$ or $R = \frac{V^2}{P}$

$$R = \frac{(220)^2}{100} = 484\Omega$$

Resistance of bulb when $V = 110$ volts

$$P' = \frac{(V')^2}{R} = \frac{(110)^2}{484} = \frac{12100}{484} = 25 \text{ W}$$

Hence answer (d) is correct.

13. Combined resistnace of 100Ω , 50Ω and 500Ω in parallel

i.e. R_p is given by

$$\frac{1}{R_p} = \frac{1}{100} + \frac{1}{50} + \frac{1}{500} = \frac{5+10+1}{500} = \frac{16}{500}$$

$$R_p = \frac{125}{4} = 31.25 \Omega$$

Resistance of electric iron = 31.25Ω

$$\text{Current through electric iron} = \frac{V}{R} = \frac{220}{31.25} = 7.04A$$

14. The power dissipated in the resistor will increase by 125 percent.

Justification using mathematical calcuations.

$$P = I^2Rt$$

When I is increased by 50% , $I' = \frac{3}{2}I$.

$$\text{Hence, } P' = I'^2Rt = \left(\frac{3}{2}I\right)^2 Rt$$

$$P' = \frac{9}{4} I^2Rt$$

$$\therefore \text{Increase in power dissipation} = \frac{9}{4} I^2Rt - I^2Rt = \frac{5}{4} I^2Rt$$

$$\therefore \text{Percentage increase} = \frac{\text{Increase}}{\text{Original}} \times 100\% = \frac{5}{4} \frac{I^2Rt}{I^2Rt} \times 100\% = 125\%$$

15. Modified circuit is as shown. Since 5Ω , 8Ω and 12Ω are in series, therefore the total resistance in series.

$$R_s = R_1 + R_2 + R_3 = 5 + 8 + 12 = 25\Omega$$

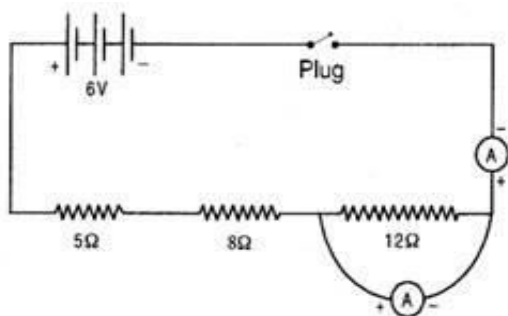

$$\text{Current through circuit } I = \frac{V}{R} = \frac{6}{25} = 0.24A$$

$$\therefore \text{Reading of ammeter} = 0.24A$$

$$= I \cdot R = 0.24 \times 12$$

$$= 2.88\Omega$$