

CBSE Test Paper-02
Chapter 13 Magnetic Effects of Electric Current

1. The device used for producing current is called **(1)**
 - a. ammeter
 - b. galvanometer
 - c. generator
 - d. voltmeter
2. At the time of short circuit, the current in the circuit **(1)**
 - a. vary continuously
 - b. reduced considerably
 - c. does not change
 - d. increases heavily
3. What does the tangent at any point on magnetic field lines indicate? **(1)**
 - a. direction of magnetic field
 - b. direction of the force
 - c. direction of current
 - d. direction of induced current
4. Match the following with correct response. **(1)**

(1) S.I unit of a magnetic field	(A) Small bar magnet capable of rotating freely
(2) The magnetic field inside the solenoid	(B) Tesla
(3) Compass needle	(C) Temporary magnet
(4) Solenoid	(D) Uniform

- a. 1-A, 2-C, 3-B, 4-D
 - b. 1-C, 2-B, 3-D, 4-A
 - c. 1-B, 2-D, 3-A, 4-C
 - d. 1-D, 2-A, 3-C, 4-B
5. Potential difference between a live wire and a neutral wire is **(1)**
 - a. 150 volt

- b. 220 volt.
 - c. 210 volt
 - d. 200 volt
6. A constant current flows in a horizontal wire in the plane of the paper from East to West as shown in the figure. At what point, the direction of the magnetic field will be North to South? **(1)**

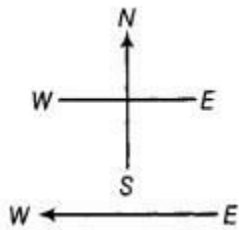

7. What is meant by magnetic field? **(1)**
8. Which is the most important safety method used for protecting home appliances from short-circuiting or overloading? **(1)**
9. In a domestic electric circuit, mention the potential difference between live wire and neutral wire and frequency of AC? **(1)**
10. Diagram shows the lengthwise section of a current carrying solenoid.
- ⊗ Indicates current entering into the page.
 - ⊙ Indicates current emerging out of the page.

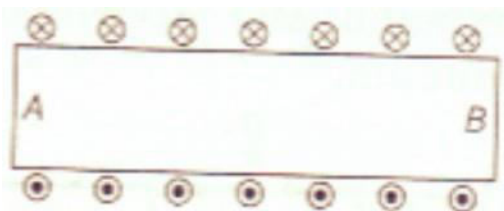

Decide which end of the solenoid A or B, will behave as North pole. Give reason for your answer. Also, draw field lines inside the solenoid. **(3)**

11. When does an electric short circuit occur ? **(3)**
12. Why don't two magnetic lines of force intersect each other? **(3)**
13. State the purpose for which the following rules are used **(3)**
- i. Right hand thumb rule
 - ii. Fleming's left hand rule
 - iii. Fleming's right hand rule
14. What is the pattern of magnetic field pattern due to current carrying conductor. **(5)**
15. Explain house hold electric circuits. What are their relative advantages? **(5)**

CBSE Test Paper-02
Chapter 13 Magnetic Effects of Electric Current

Answers

1. c. generator

Explanation: Electric current is produced by electric generator which converts mechanical energy into electricity.

2. d. increases heavily

Explanation: A **short circuit** is simply a low resistance connection between the two conductors supplying electrical power to any **circuit**. This results in excessive current flow in the power source through the '**short**,' and may even cause the power source to be destroyed.

3. a. direction of magnetic field

Explanation: Tangent indicates the direction of the magnetic field. It just an alternative used when compass is not available

4. c. 1-B, 2-D, 3-A, 4-C

Explanation:

- i. The tesla (symbolized T) is the standard unit of magnetic flux density.
- ii. A solenoid is a tightly wound helical coil of wire whose diameter is small compared to its length. The magnetic field generated in the centre, or core, of a current carrying solenoid is essentially uniform, and is directed along the axis of the solenoid.
- iii. The needle of a magnetic compass is 'just' a small bar magnet that is balanced carefully so it can rotate freely.
- iv. Solenoid is temporary strong magnet, when connected through external source like battery or when electricity passed through it. It is also known as electromagnet.

5. b. 220 volt.

Explanation: In our country the potential difference between the live and neutral wire is 220 V and the frequency is 50 Hz.

6. According to the right-hand thumb rule, the curve of the fingers represents the

direction of the magnetic field. If the wire is grasped in the right hand then the direction of magnetic field will be from North to South.

7. Magnetic field is a region around a magnetic material in which the force of magnetism acts. It is a vector quantity
8. **FUSE** must be used to prevent shocking, overloading and short-circuiting in domestic appliances.
9. Potential difference in between live wire and neutral wire domestic circuit is 220 volt frequency of AC is 50 Hz.
10. From diagram, we can see that current is entering from A and emerging out from B.

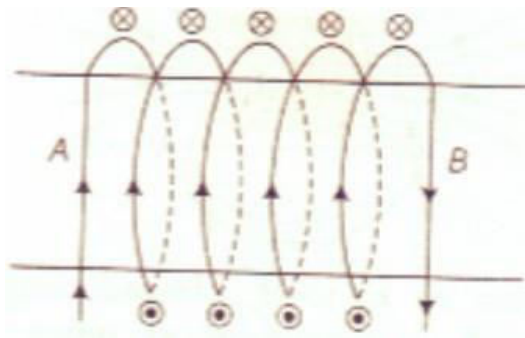

Thus, using right hand thumb rule, direction of magnetic field lines is from B to A.

Thus B represent N pole and A represent S pole, as we also know that, magnetic field lines move from North to South direction outside the solenoid.

11. Electric short-circuit occurs when :
 - (a) live wire incidentally touches neutral or earth wire
 - (b) Insulation gets hardened by the excessive use.
 - (c) current passed through wire is more than its rating.
 - (d) insulation around the current carrying wires is weak.
12. No, two magnetic field lines can ever intersect each other. If they do, then it would mean that at the point of intersection there are two directions of magnetic field, which is not possible.
13.
 - i. The **right-hand thumb** rule is used to find the directions of the magnetic field around a current carrying straight conductor.
 - ii. **Fleming's left-hand rule** (motor rule) helps in understanding the direction of the magnetic force acting on a conductor.
 - iii. **Fleming's right-hand rule** (dynamo rule) helps in understanding the direction of induced current when a conductor moves in a magnetic field.

ends of the wire are connected to a battery as shown in fig. When the key is closed, the current flows through the wire from B to A as shown in fig. (a), it produces magnetic field around it

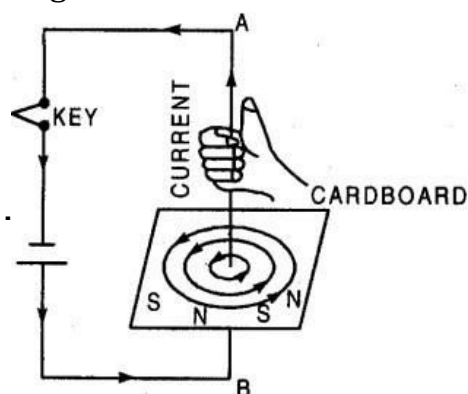
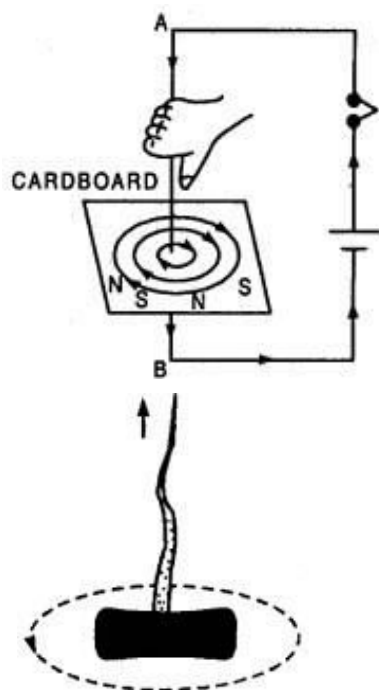

fig. (a)

The magnetic lines of force can be drawn with the help of a compass needle. The magnetic lines of force can also be visualized by sprinkling iron filings on the cardboard. On tapping the cardboard sheet, the iron filings arrange themselves in circles around the wire. The direction of the field is indicated by compass needle (a) The direction of magnetic field is given by right hand grip rule and by right hand cork screw rule.

Right hand grip rule is stated below : Grasp the wire in the right hand so that the thumb points along the wire in the direction of current, the fingers will then point in the direction of magnetic field.



Right hand cork-screw rule : Imagine a right handed cork-screw to be lying with its direction coinciding with the conductor carrying current and to be revolved so that it travels in the direction in which thumb rotates gives the direction of lines of force.

15. There are two system of circuits :

- i. Tree system : Electricity supplied to us for domestic purposes is 220 V and A.C. The current alternates its polarity 50 times in 1s i.e., its frequency is 50 Hz., 15 A switches and 15 A sockets are used where heavy currents are to be drawn e.g., in hot air blower, motor, geyser etc. and 5 A switches, sockets are used for bulbs, tubes, radio, C.T.V., refrigerator fans etc. The main supply is delivered to houses using a three-core wiring called live, neutral and the earth. The live wire is red (or brown) in colour and brings current. It is dangerous to touch live wire with bare hands. Neutral is black (or light blue) coloured wire and is used as return wire. The third wire, green (or yellow) in colour is earth wire. Earth may be taken from pole or a metal plate sunk deep in the earth. It is safety measure and does not in any way affect the supply. Earth is usually connected to the body of the electric appliances. If at any time, the live wire incidentally touches the body of the electric appliance, the earth wire sends the current from the body of the appliances to the earth. Each appliance has a separate switch connected across live wire. The neutral reaches the appliance directly. All the appliances are connected in parallel so that switching off one circuit does not affect the other section. The parallel circuit also ensures that each appliance is connected to same voltage

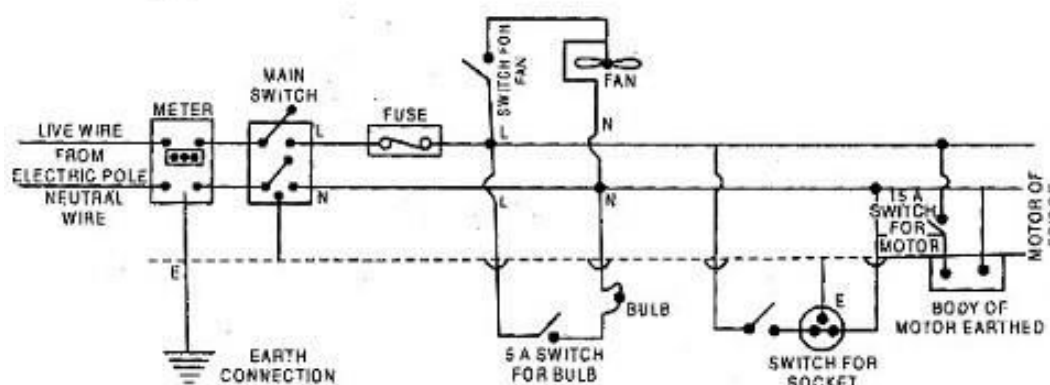

Advantages of tree system : Disadvantages of tree system:

- a. Since all appliances are in parallel, each appliance gets optimum current.
- b. Since all circuits are in parallel, P.D. at the ends of each appliance remains the

- same.
- c. Each circuit is independent of the other. If there is a short-circuiting in one circuit then only the fuse in that circuit gets melted. Power supply to the other circuit remains unaffected.
 - d. Plugs and sockets to different amperage for different appliances are required.
 - e. Since all the circuits start from main distribution board, therefore, longer lengths of the wire are required for each circuit. It increases the cost of wiring system.
 - f. Installation is fairly time consuming
- ii. Ring system of household wiring: Ring system consists of a ring-circuit starting distribution board and running around every corner and returns back to the distribution board again. There are two routes through which the current can flow through various appliances. Hence, a wire of lower rating may be used thus reducing the cost of installation.

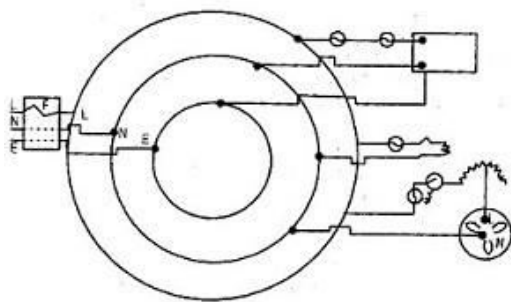

Advantages of ring system

- a. All appliances have separate fuse. In case of short-circuiting, only one fuse goes away.
- b. Its installation and maintenance is cheaper.
- c. Since ring feeds whole house, the length of the wire used is much smaller. It is cost-saving.